

5 amp sensorless motor drivers

Small, compact, no programming or set up required. Up to 99% efficiency, no inductors required for slotless or ironless motors.

Table of Contents

S24V5A-4 Digital closed and open loop drives with speed, direction, brake inputs and tach output.....	2
S24V5A-3 Digital closed and open loop drives with speed, direction, motor temperature inputs and tach outputs....	6
Analog open loop drives S24V5A-1, and S24V5A-2	9
CV1 braking module.....	10
Speed pot with leads.....	11
Technical notes and application information.....	12

S24V5A digital closed sensorless motor driver with brake 5A 10-34V

Ultra high efficiency miniature sensorless digital drive with 37kHz pwm frequency, designed for use with stand alone, digital or analog operation. The digital design has a sophisticated start up which will start higher inertia loads than is typical for sensorless drives. The drive can be programmed for open or closed loop speed control and can be custom programmed for your specific application. The drive has no minimum inductance and will operate slotless or ironless brushless motors without the need for bulky, cumbersome inductors. For stand alone operation the optional speed pot can be ordered. Once power supply, motor and speed pot are connected, the motor can be operated without the need for any adjustments, set up or programming. For digital operation the unit will interface with a customers microcontroller. The microcontroller should be 5v or be a 3.3v with 5v interface capabilities. Speed input can be accomplished with a 0-5v analog input (less then 1mA) or a 100 hz to 100k Hz square wave with variable duty cycle. For operation in a single direction such as a pump, blower or beam chopper only power, the three motor leads, and the 0-5v speed input (or the speed pot) need to be connected. If reversible operation is required a SPDT switch can be added between DR and P- or a 0 or 5 volt signal from a microcontroller to DR can be used. If the switch is open the motor will run in the clockwise direction, if the switch is closed the motor will run in the counterclockwise direction. The Tach output is referenced to P-, and is a 5 volt square wave at 3 pulses per revolution per magnet pole pair (1000 hz=20,000 rpm, 2 pole motor). The EN input will turn off the motor if pulled to ground. To apply brake connect BK to P+ with a swich, or use an external 5v signal connected between BRK and P-. The CV-1 braking module should be used when braking if the drive is used with a power supply instead of a battery. The drive can be custom programmed for your specific application, for example to run at a fixed speed when power or the enable is applied. The drive weighs 1.9 oz.

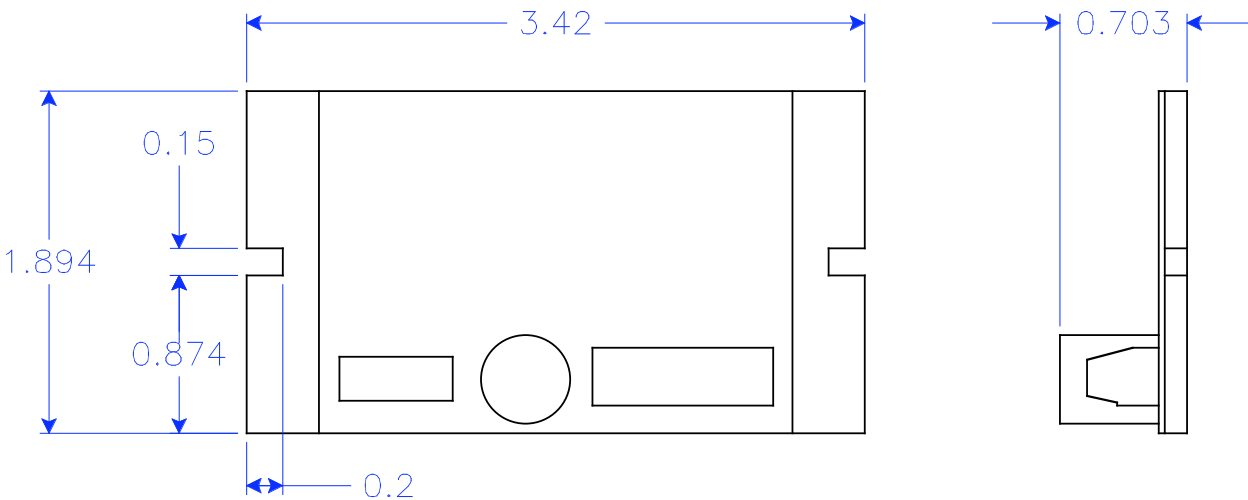
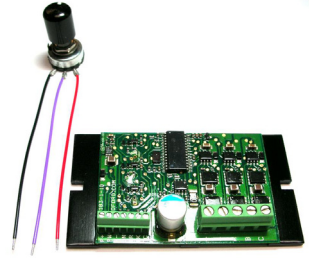

Terminal block positions (motor lead hook up for Koford motors).

P+=connect to one side of pot (5.0v) (red)
 PW=connect to pot wiper (center terminal) (purple)
 P-=connect to other side of pot (ground) (black)
 EN=unconnected or 5v to run, 0v to turn motor off
 DR=leave unconnected for forward direction, hook to P-
 for reverse
 BK=unconnected or 0v=off, 5v=on

TC=tach/encoder output 3 pulses per revolution
 per magnet pole pair (1000 hz=20,000 rpm, 2 pole
 motor)
 -=Connect to black (-) lead of power supply
 +=Connect to red (+) lead of power supply
 A=blue motor wire
 B=white motor wire
 C=brown motor wire

Ordering information:

please send the order to mail@koford.com

Part number: S24V5A-4H closed loop drive 5k rpm 2p, 2.5k rpm 4p, 1.25k 8p
S24V5A-4B closed loop drive 10k rpm 2p, 5k rpm 4p, 2.5k rpm 8p
S24V5A-4C closed loop drive 20k rpm 2p, 10k rpm 4p, 5k rpm 8p
S24V5A-4D closed loop drive 40k rpm 2p, 20k rpm 4p, 10k rpm 8p
S24V5A-4E closed loop drive 80k rpm 2p, 40k rpm 4p, 20k rpm 8p
S24V5A-4F closed loop drive 120k rpm 2p, 60k rpm 4p, 30k rpm 8p
S24V5A-4G closed loop drive 200k rpm 2p, 100k rpm 4p, 50k rpm 8p
S24V5A-4I closed loop drive 300k rpm 2p, 150k rpm 4p, 75k rpm 8p
S24V5A-4A open loop drive 100k rpm 2p, 50k rpm 4p, 25k rpm 8p
P1 pot with knob and leads

The closed loop speed control drives control the motor speed rather than duty cycle so that speed will remain steady under varying load. The drive is off at 0-.5v and then the speed ramps from the minimum up to the maximum as the pw voltage is increased. The duty cycle is automatically adjusted as needed to maintain speed under varying load conditions. At turn on the motor speed ramps to set speed in 1-2 seconds. For most applications the closed loop speed control is preferred.

The -4A version has open loop speed control. The motor is off with a pw voltage of 0-.5V, and the duty cycle increases linearly from the minimum level up to 100% when pw=5.0v. Maximum speed with a two pole slotless motor is 100,000 rpm. This type will respond immediately to the speed command.

The minimum speed depends on the motor and the load but is usually 20% to 50% of the motors no load speed.

Basic configuration

Rotation for Koford motors is clockwise as viewed from the motor mounting surface. Motor direction can be reversed by switching Blue and White leads

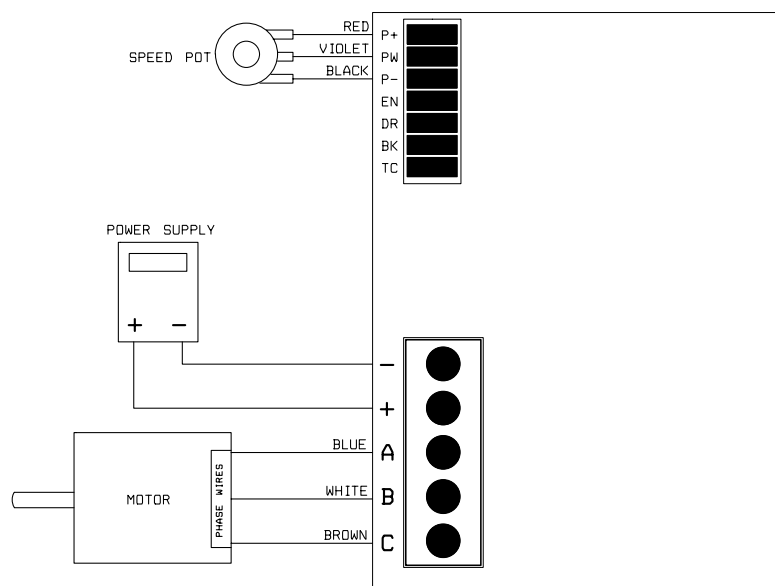

Stand alone operation with speed pot and brake

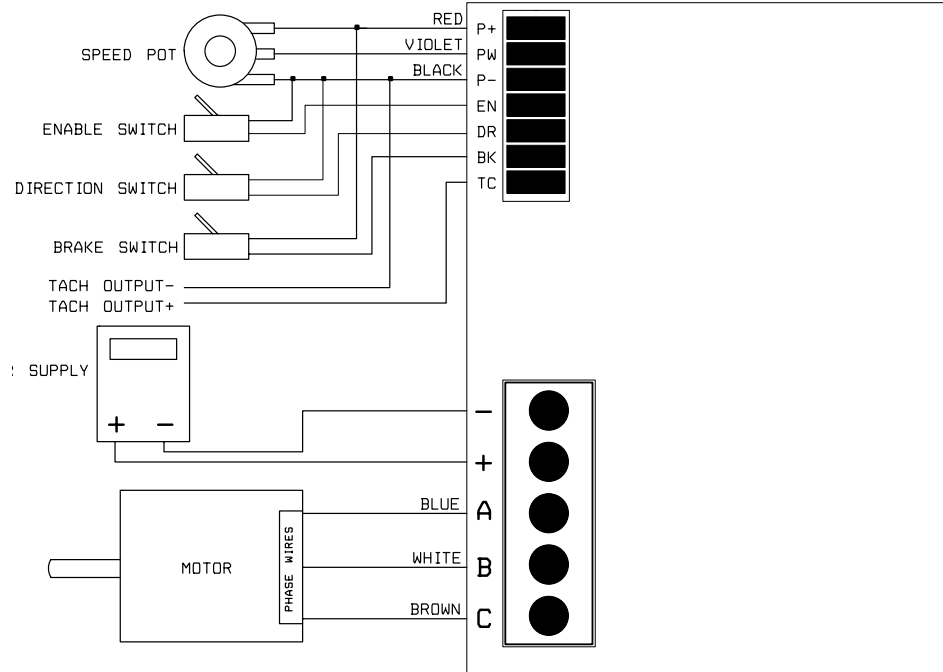

External control

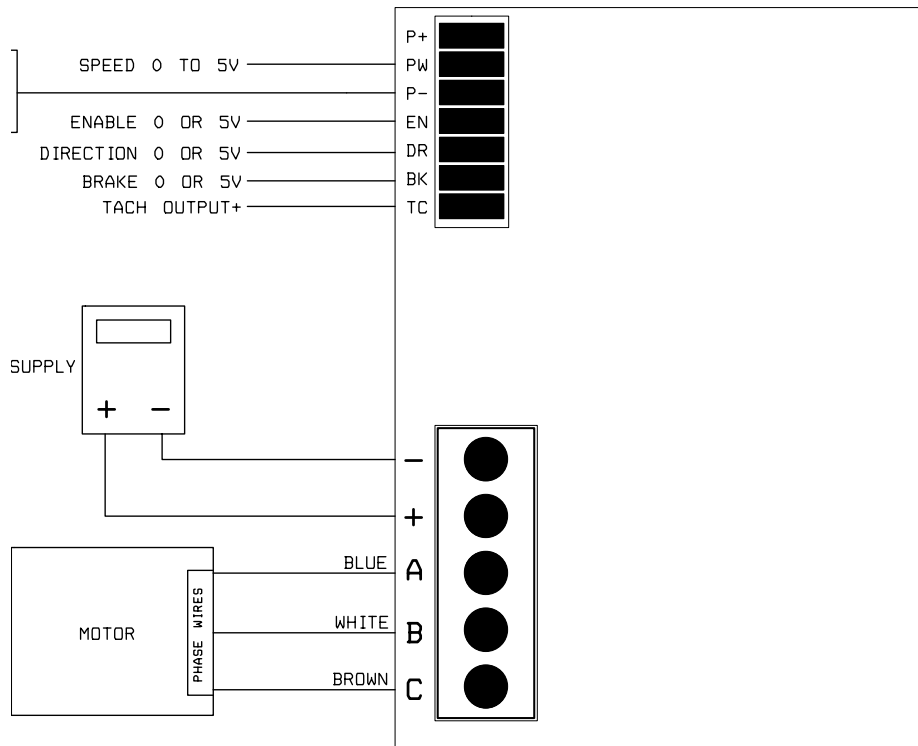

S24V5A - 4A
command input vs percent of full speed

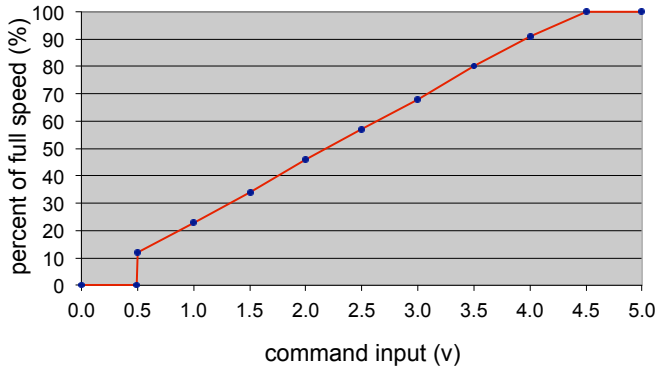

S24V5A - 4B
command input vs speed

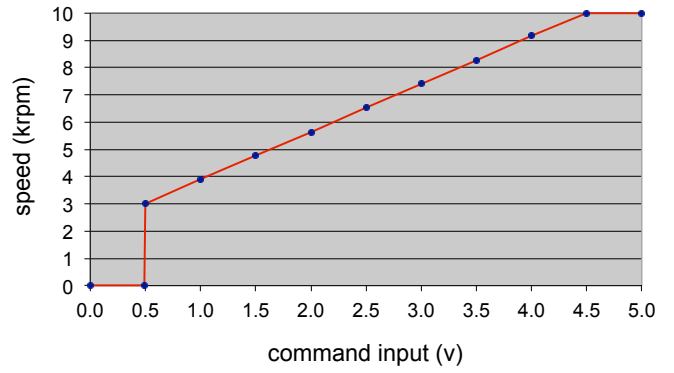

S24V5A - 4C
command input vs speed

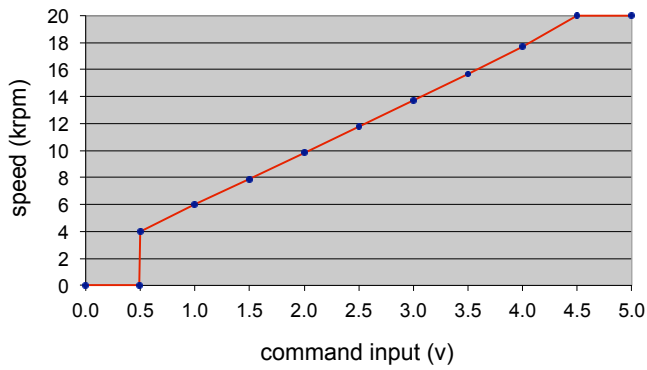

S24V5A - 4D
command input vs speed

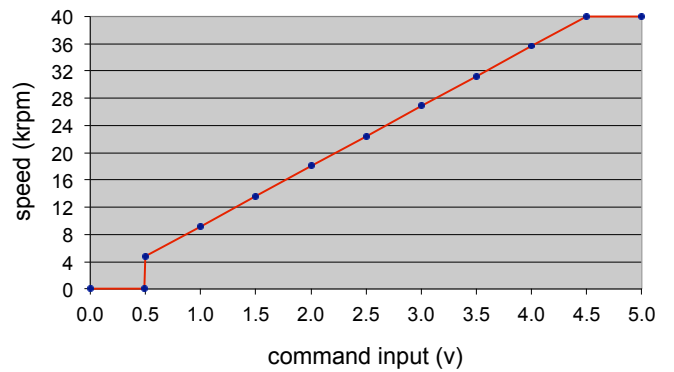

S24V5A - 4E
command input vs speed

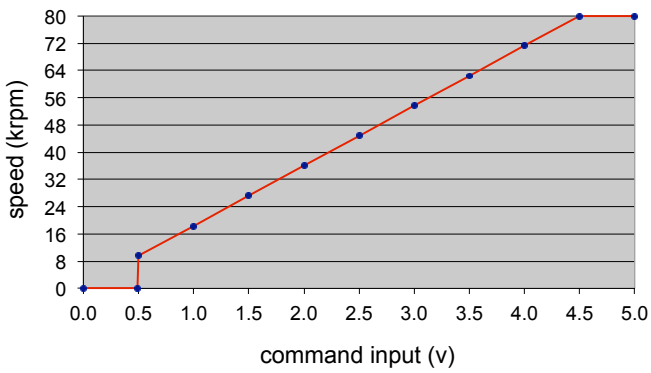

S24V5A - 4F
command input vs speed

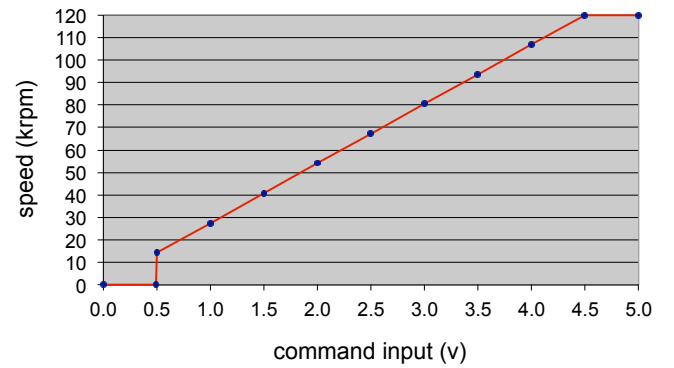

S24V5A - 4G
command input vs speed

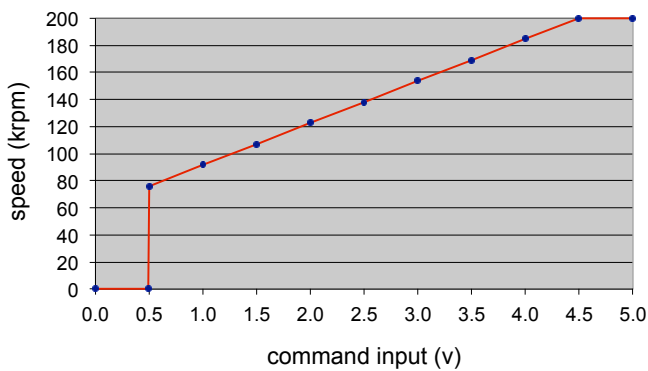

S24V5A digital closed sensorless motor driver with temperature protection 5A 10-34V

Ultra high efficiency miniature sensorless digital drive with 37kHz pwm frequency, designed for use with stand alone, digital or analog operation. The digital design has a sophisticated start up which will start higher inertia loads than is typical for sensorless drives. Open loop and closed loop versions are available and the drive can be custom programmed for your specific application. The drive has no minimum inductance and will operate slotless or ironless brushless motors without the need for bulky, cumbersome inductors. For stand alone operation the optional speed pot can be ordered. Once power supply, motor and speed pot are connected the motor can be operated without the need for any adjustments, set up or programming. For digital operation the unit will interface with a customers microcontroller. The microcontroller should be 5v or be a 3.3v with 5v interface capabilities. Speed input can be accomplished with a 0-5v analog input (less than 1mA) or a 100 hz to 100k Hz square wave with variable duty cycle. For operation in a single direction such as a pump, blower or beam chopper only power, the three motor leads, and the 0-5v speed input (or the speed pot) need to be connected. If reversible operation is required a SPDT switch can be added between DR and P- or a 0 or 5 volt signal from a microcontroller to DR can be used. The Tach output is referenced to P- and is a 5 volt square wave at 3 pulses per revolution per magnet pole pair (1000 hz=20,000 rpm, 2 pole motor). The temperature input interfaces directly with the thermistor output of a Koford motor and turns off the motor if a winding temperature of 150°C is reached, when the winding temperature drops to 100°C the motor will restart. If the motor does not have temperature sensors then these connection can be left open. The drive can be custom programmed for your specific application. The drive weighs 1.9 oz.

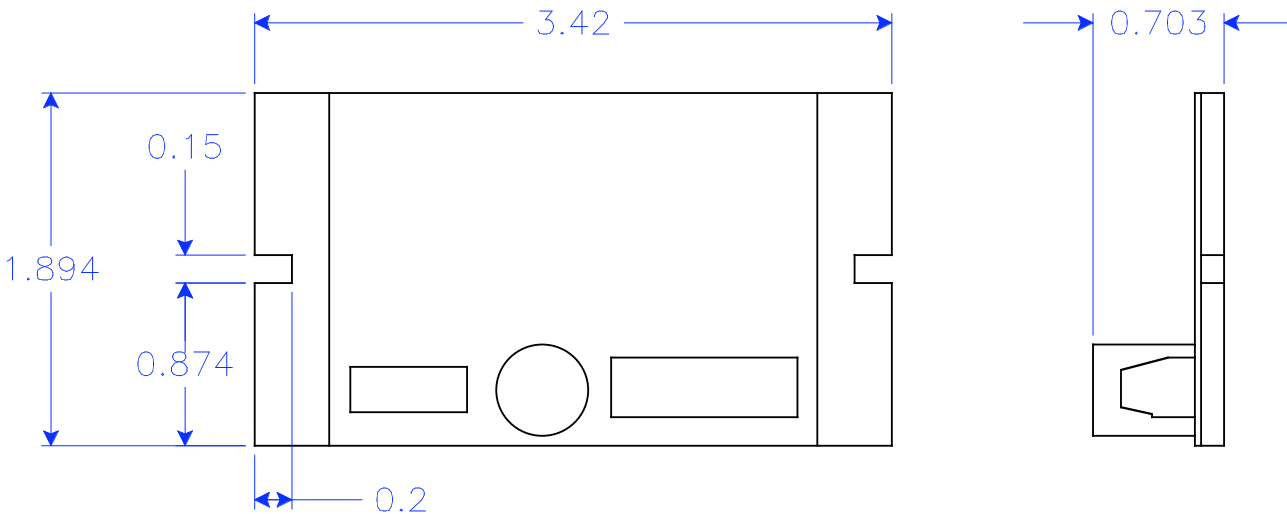
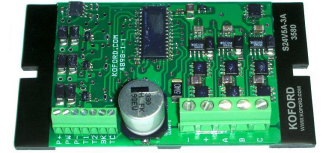

Terminal block positions (motor lead hook up for Koford motors).

- P+=connect to one side of pot (5.0v) (red)
- PW=connect to pot wiper (center terminal) (purple)
- P-=connect to other side of pot (ground) (black)
- DR=leave unconnected for forward direction, hook to P- for reverse
- T1=Temp sensor, leave disconnected if not used
- T2=Temp sensor, leave disconnected if not used

- TC=tach/encoder output 3 pulses per revolution per magnet pole pair (1000 hz=20,000 rpm, 2 pole motor)
- =Connect to black (-) lead of power supply
- + =Connect to red (+) lead of power supply
- A=blue motor wire
- B=white motor wire
- C=brown motor wire

Ordering information:

please send the order to mail@koford.com

Part number: S24V5A-3B closed loop drive 10k rpm 2p, 5k rpm 4p, 2.5k rpm 8p
S24V5A-3C closed loop drive 20k rpm 2p, 10k rpm 4p, 5k rpm 8p
S24V5A-3D closed loop drive 40k rpm 2p, 20k rpm 4p, 10k rpm 8p
S24V5A-3E closed loop drive 80k rpm 2p, 40k rpm 4p, 20k rpm 8p
S24V5A-3F closed loop drive 120k rpm 2p, 60k rpm 4p, 30k rpm 8p
S24V5A-3A open loop drive for use above 40k rpm, 183k rpm 2p
P1 pot with knob and leads

The -3A version has open loop speed control. The motor is off with a PW voltage of 0-.5V, and the duty cycle increases linearly from the minimum level up to 100% when pw=5.0v. Maximum speed with a two pole slotless motor is 183,000 rpm. this version provides rapid response to a speed command. The closed loop versions control the motor speed rather than duty cycle so that speed will remain steady under varying load. The drive is off at 0-.5v and then the speed increases from the minimum up to the maximum as the pw voltage is increased. The duty cycle is automatically adjusted as needed to maintain speed under varying load conditions. for most applications the closed loop speed control should be used.

The minimum speed depends on the motor and the load but is usually 20% to 50% of the motors no load speed.

Stand alone operation with speed pot and motor temperature sensor

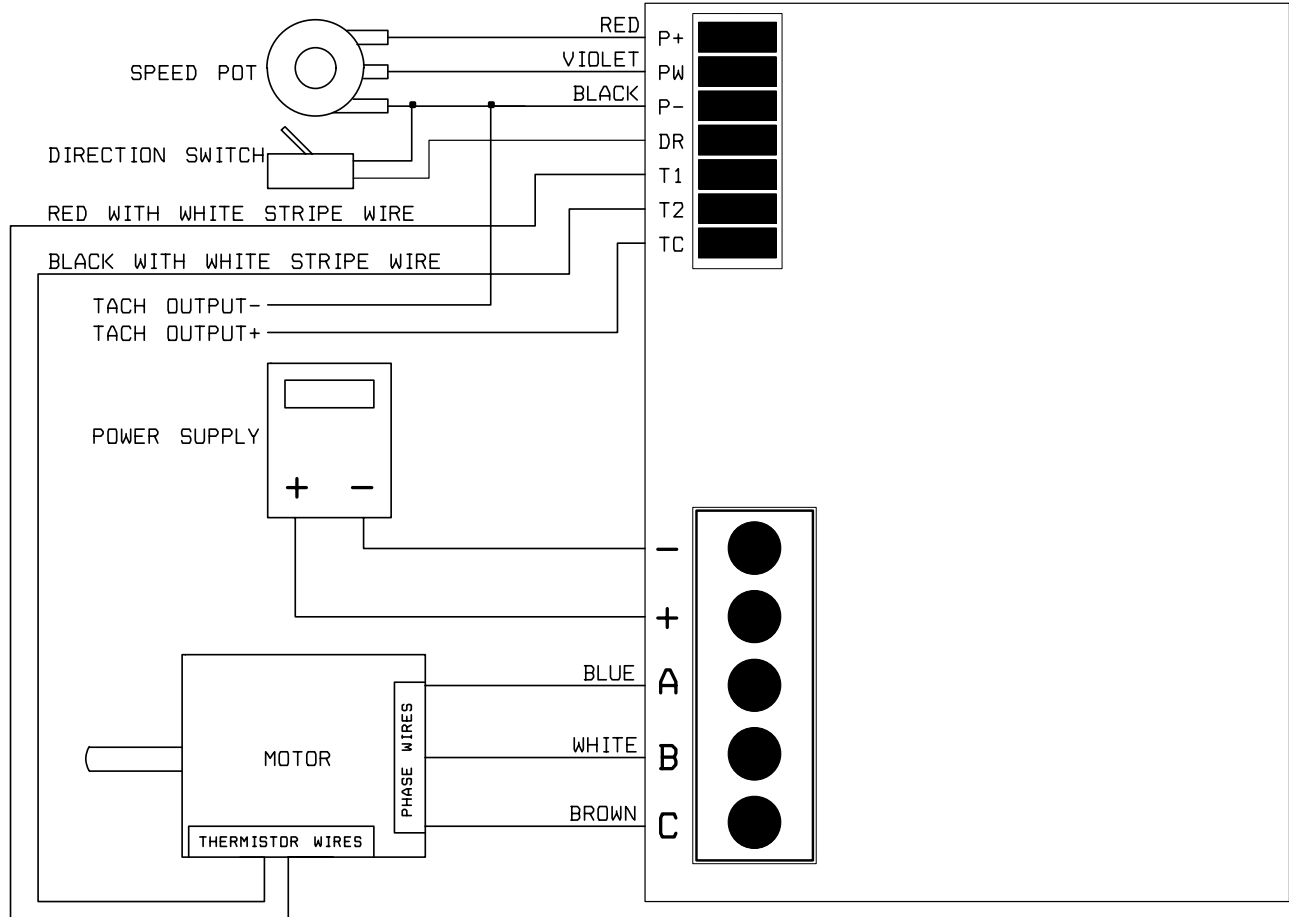

S24V5A - 3A
command input vs percent of full speed

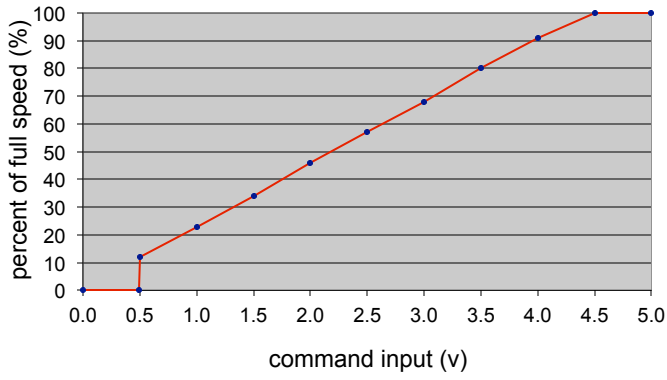

S24V5A - 3B
command input vs speed

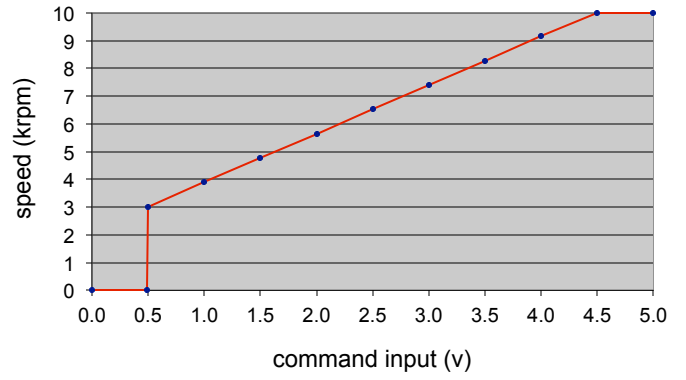

S24V5A - 3C
command input vs speed

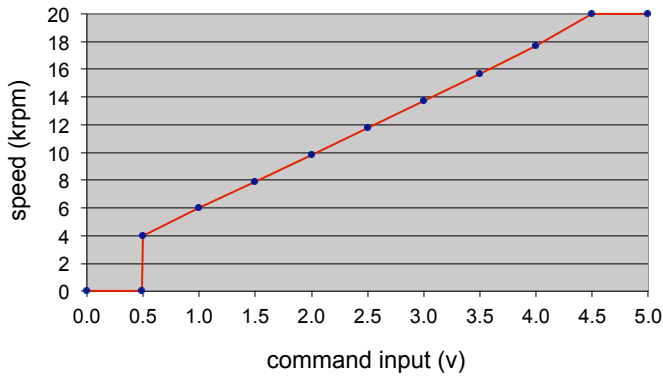

S24V5A - 3D
command input vs speed

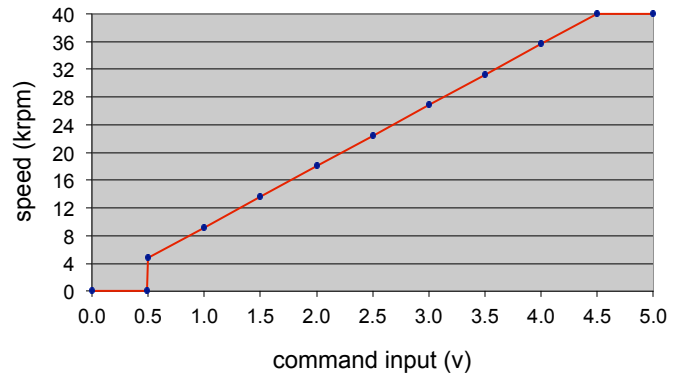

S24V5A - 3E
command input vs speed

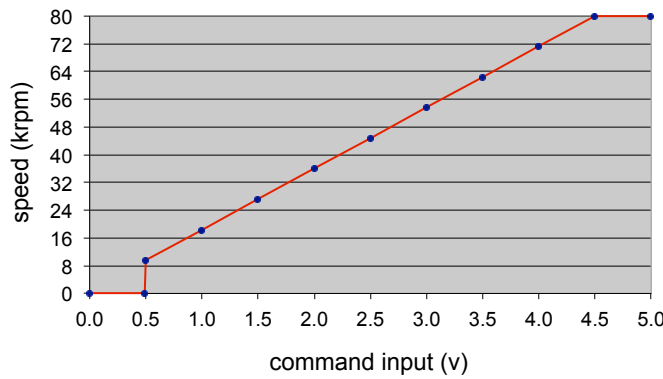

S24V5A - 3F
command input vs speed

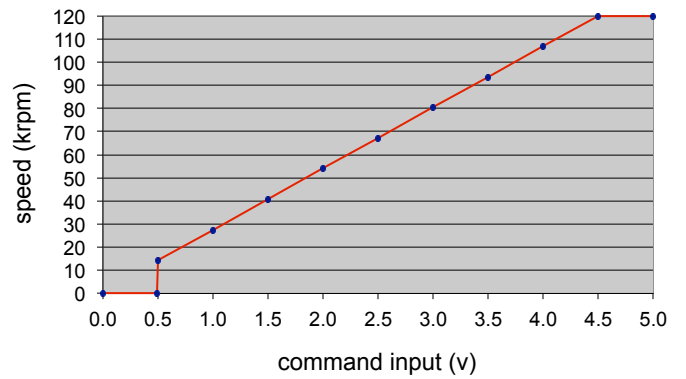

Analog ultra high efficiency miniature sensorless drive with 63kHz pwm frequency, designed for use with speed pot or 0-5v control input. The drive has no minimum inductance and will operate slotless or ironless brushless motors without the need for bulky, cumbersome inductors. Two types are available, a full featured -1 model which include tach and current output, and open loop speed control, and a lower cost -2 which deletes the tach and current output. The high PWM frequency reduces motor heating when operating at less than full speed. For stand alone operation the optional speed pot can be ordered. Once power supply, motor and speed pot are connected the motor can be operated without the need for any adjustments, set up or programming. If reversible operation is required a SPDT switch can be added between Dir and P-. Speed input can be accomplished with a 0-5v analog input (less than 1mA) or a 100 hz to 100k Hz square wave with variable duty cycle. For best results a RC filter should be used. The direction is controlled by 0v (reverse) or 5v (forward) to the DR input. The current output is a DC voltage at .5v per amp of motor current (not power supply current). For analog operation the TC output can be connected to a one shot, filtered and a DC voltage proportional to the rpm will result. This drive will operate to 90,000 rpm with a 2 pole slotless motor. The drive weighs 1.9 oz.

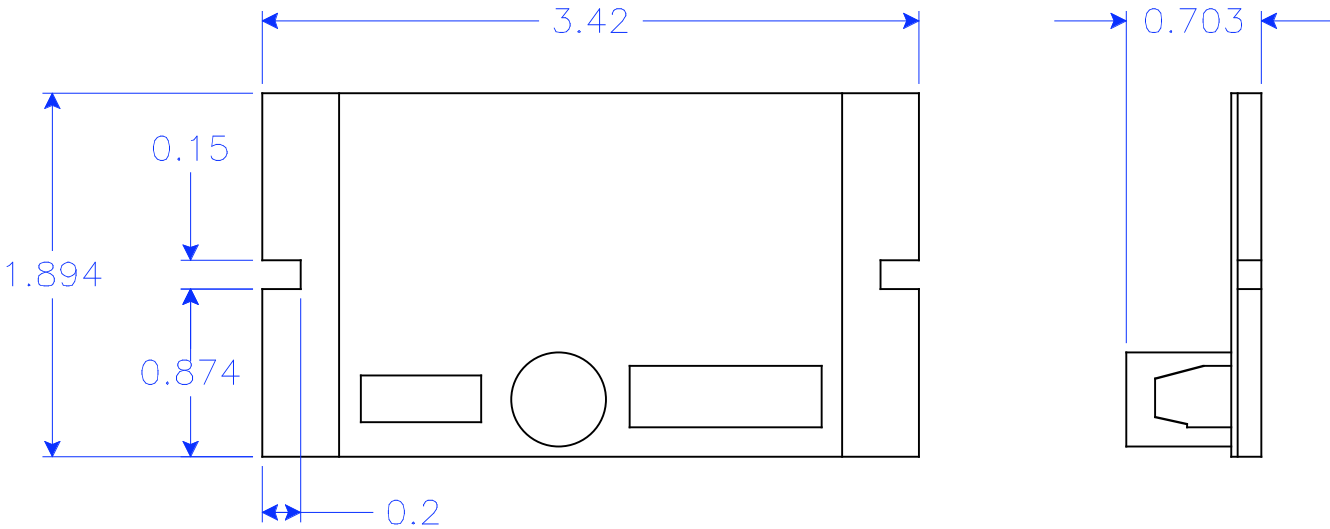
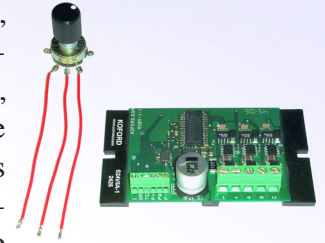

Terminal block positions (motor lead hook up for Koford motors)
 I=current output, .5V = 1A of motor current
 DR=leave unconnected for forward direction, hook to P- for reverse
 TC=tach/encoder output 3 pulses per revolution per magnet pole pair (1000 hz=20,000 rpm, 2 pole motor)

P+=connect to one side of pot (5.0v)
 PW=connect to pot wiper (center terminal)
 P-=connect to other side of pot (ground)
 -=Connect to black (-) lead of power supply
 +=Connect to red (+) lead of power supply
 A=blue motor wire
 B=white motor wire
 C=brown motor wire

Ordering information:

mail@koford.com•phone 937-695-1275•fax 937-695-0237•www.koford.com

Part number: S24V5A-1 Full featured drive, tach, direction, current
S24V5A-2 Drive with direction
P1 Optional pot

The CV-1 braking module is for use when a drive with braking function is connected to a power supply. If a battery supplies the power, the module is not needed. The module is needed on a system with a power supply because otherwise the regenerated energy would cause an overvoltage condition in the power supply. That would cause power supply shut off and/or power supply damage. The module contains Schottky diodes to prevent current backflow and also a TVS to absorb the transient braking energy. The TVS is needed because otherwise the braking energy would cause an overvoltage in the drive damaging it.

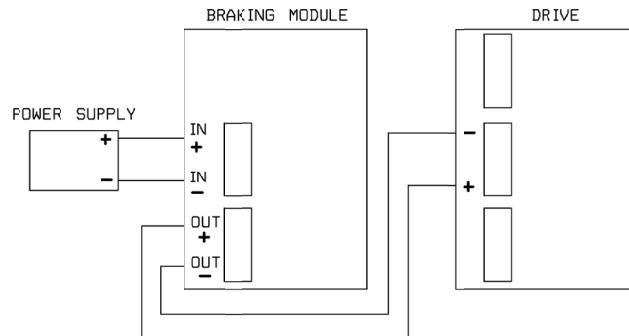
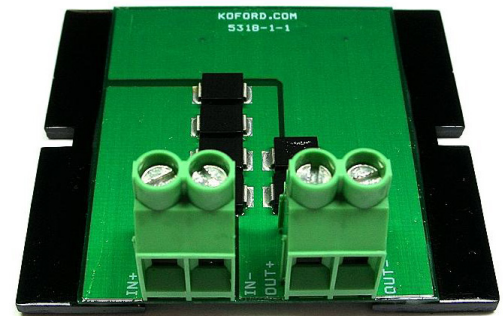
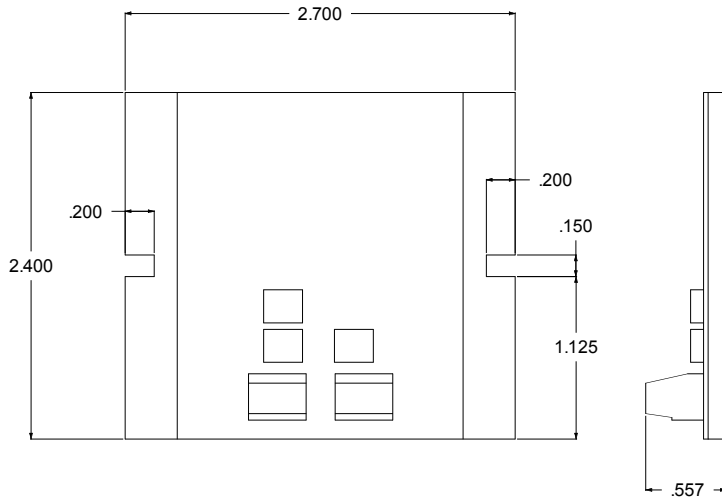

SPEED POT AND KNOB

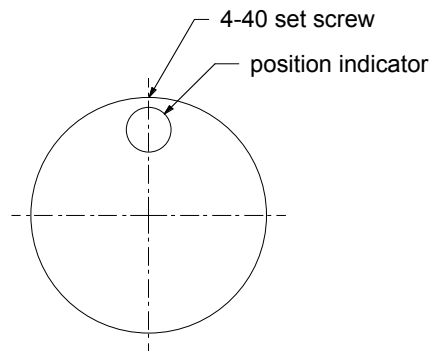
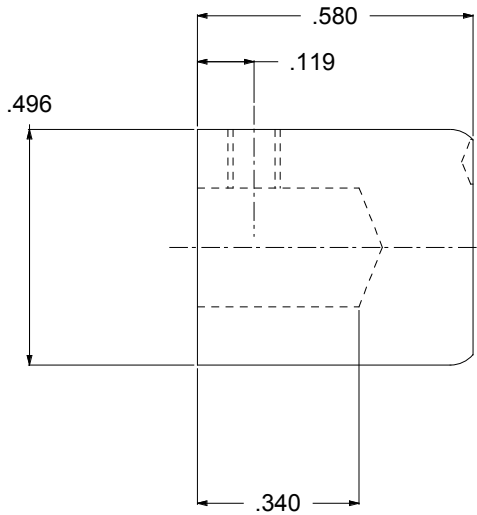
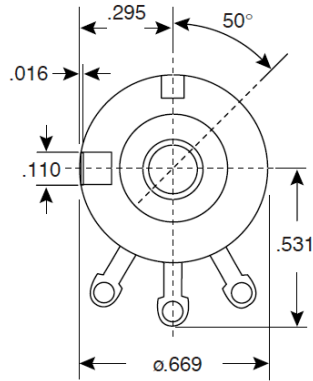
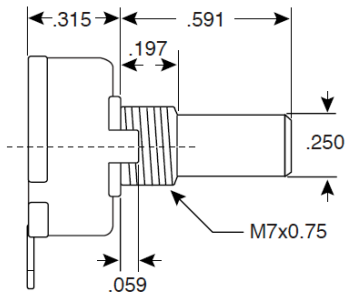
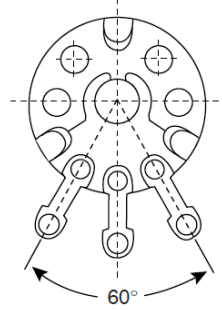
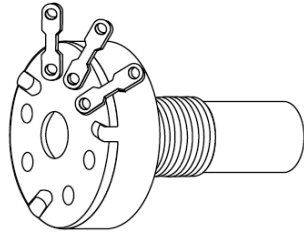

Leads are 3.440" long stranded 22 gauge with TFE insulation.

Notes

1. Sensorless drives work best with slotless or ironless brushless motors. Most slotted motors will work reasonably well but a few will not.
2. The maximum speed depends on the characteristic of the motor, however Koford 2 pole motors will run well up to 80,000 rpm with these drives (96,500 for open loop digital drive) and 4 pole motors up to 40,000 rpm (48,250 for open loop digital drive). Slotted motors will have a lower maximum speed and may not be able to reach full current without stalling if they have a high pole count and large inductance. This must be determined by testing. The greater the inductance and the larger the pole count the lower the maximum speed and allowable load will be.
3. When using a microcontroller to operate the drive a 5 volts signal should be used and the pwm frequency should be 8Khz or more, otherwise filtering of the output will be required.
4. The drive's current output (-1 drives only) shows motor current, this is not the same as power supply current. A pwm drive acts much like a variable transformer to reduce the voltage and at the same time increase the current delivered to the motor. For example if the speed pot is set to 10% of maximum speed and the power supply shows 0.5 amp and 24 volts, the motor will see approximately 5 amps and 2.4 volts. This current sense output is approximate and is most accurate near full load current. The current can be used to indicate motor load or for use in current mode control.
5. The current limiting of the drive limits the current delivered to the motor to slightly above 5 amps, this means that the current at the power supply will reach a maximum of slightly above 5 amps with the speed turned to maximum, if the speed is reduced then the current at the power supply will be proportionately reduced so as to maintain the current at the motor at a maximum of 5 amps.
6. The drive should preferably be mounted on a aluminum chassis or frame, or a aluminum heat sink. Drive heat rise is greatest at high currents, low duty cycles and continuous operation. If the application is 100% duty cycle, with normal indoor ambient temperature, the current is low compared to the rated current, or if the application is intermittent with on times for example of 1 minute and off times of at least 1 minute, then a heat sink will probably not be necessary. For high ambients forced air cooling directed at the board can help. For long term reliability, it is recommended that sufficient cooling be provided to prevent the hottest spot on the board from exceeding 100C. This can be checked with a portable infrared thermometer
7. Sensorless motors cannot operate near zero speed as they need back emf to determine the correct point of commutation. There is also a minimum duty cycle required for proper commutation which limits the speed range. If the motor has no load then the speed range may only be 50% to 100% depending on the motor. With a slight load the speed range increases to 20% to 100%. At 50% of rated current the range is 10% to 100%. These values are approximate and depend on motor inductance, efficiency, and input voltage. If a wider speed range is required then the input voltage can be reduced to allow lower rpm or if that is not sufficient hall sensor motors and drives should be used.
8. The motor direction should only be reversed when the motor is stopped. Otherwise excessive voltages and currents can be produced potentially damaging the power supply and/or the drive.
9. Drives with the brake function regenerate the energy of the spinning motor and its load back to the power source when the brake input is activated. If the power source is a battery the battery will be recharged. For use with a power supply the CV-1 braking module should be used which will dissipate the energy of the spinning load (up to 10x the motor inertia) and isolate the voltage from the power supply preventing power supply over-voltage damage. For higher inertia loads use the CV-2 braking module.

10. -3 and -4 versions can be factory programmed with custom features and start up can be modified to meet customer requirements. These versions are most suitable if a soft start up or a difficult to start load is involved. -3 and -4 versions are available with closed loop speed control or open loop speed control. Other options such as controlling the speed according to an input from a thermistor or pressure sensor are also possible. The standard start up for the -3 and -4 is a ramp up that takes 200ms. The drive takes an additional 100ms to start up when power is turned on. If rapid start is desired the drive should be powered up and the enable used to start the motor instead of turning power to the drive on and off. The -3 and -4 will start higher inertia and more difficult loads and the start up may be custom programmed for a specific motor and load if necessary. The open loop control version responds to a 0-5 volt signal on the PW input which can come from a microcontroller using a pwm output (8kHz or higher frequency), the optional speed pot, or an analog voltage. If the motor is stalled the drive will shut off after .1 seconds. After waiting for .5 seconds the drive will attempt to restart. This will continue until the motor starts. This will not damage the motor or drive. When the speed input is set to zero volts the motor is turned off. If the input voltage is increased above .5 volts then the motor is started and runs at the minimum 15% duty cycle. If the speed input voltage is reduced below .5 volts the motor shuts off.

11. The -1 and -2 are open loop speed control only and start up is with 100% duty cycle so these drives will pull more current at start up than the -3 and -4. The motor will run at the minimum speed if the speed input is turned all the way down, to shut off the motor the input power must be shut off.

12. The direction of the motor can be changed with the direction input or by switching any two motor leads. On the -3 and -4 if the direction must be changed during operation then the motor will first stop before changing direction. On the -1 and -2 power should be shut off to the drive or at least the speed must be turned down to the minimum and time allowed for the motor to drop down in speed before the direction input is changed.

13. The -3 has a thermistor input. This input is for motors equipped with thermistor temperature sensors for overtemperature protection and is designed for the 5k sensor used in Koford motors. If the motor winding exceeds 150°C then the motor shuts until the temperature drops back below 150°C. Optionally the drive can be programmed to shut down until the power is cycled.

14. The drives are programmed at the factory and does not require any programming, switches or adjustments by the user. The units are plug and play.

15. Precise speed control is possible with closed loop control (even ± 1 rpm) but this is very much dependent on the motor (especially the bearings) and the stability of the power supply, and requires a constant load and speed command. $\pm 0.5\%$ is easily achievable for most motors for a steady load. For the highest precision and lowest settling time the use of an encoder, closing the speed loop with the encoder in an external user supplied speed control loop is recommended.

16. The drive will operate both slotless and slotted motor, however results will be better with slotless motors. Slotted motors with a severe cog will be difficult to start especially if there is also a high inertia load. Designing the motor with low cog through the selection of the number of magnets and slots, as well as slot dimensions helps. Often skewing the magnets or laminations can greatly reduce cogging. Increasing the air gap also helps. Some lamination designs cannot be operated with a sensorless drive due to multiple back emf zero crossings, or near zero slope at the zero crossing. These problems can usually be remedied with sufficient skewing.